

## **WEATHERING OF BERNESE SANDSTONES**

C. BLAEUER

Mineralogisch-petrographisches Institut, Universitaet Bern, Suisse

### **Abstract**

The main decay phenomenon of Bernese sandstone is a granular disaggregation. Less frequent, but more specific to these rocks, is a swelling that can be observed in marl-free stones. In stones containing common marl clasts this swelling is not observed.

Marl-free and marl-containing Bernese sandstones behave differently with respect to water absorption through capillary forces, drying and the location of salt precipitation.

### **1. INTRODUCTION**

The "Bernese Molasse sandstone" is the main historic building stone in the Bernese area of Switzerland. Originally it was used locally, but then towards the end of last century, with the extension of transport facilities, particularly rail-ways, the stone was also exported to other regions of Switzerland. At this time very richly ornamented facades became fashionable and this rather weak stone was therefore widely used, as it was a cheap and easy to dress building stone (5). Today these sandstones can be found in buildings of all towns on the Swiss Plateau (Mittelland). However, this stone is susceptible to considerable weathering processes and nowadays the conservation of this rock causes very serious problems.

This contribution is a part of a thesis with a wider scope on the weathering of Bernese sandstones.

### **2. GEOLOGY AND MINERALOGY**

There are three Molasse sandstones that are mainly used for building in Switzerland. These comprise the "Granitic sandstone", the "Platten sandstone" and the "Bernese sandstone". Granitic and Platten sandstones both belong to the Subalpine Molasse, with the former being deposited in freshwater and the latter in marine environments. Their geology, mineralogy and weathering properties were discussed by Zehnder (8), (9).

The Bernese sandstones belong to the Autochthonous Molasse. They are found in a broad strip, about 200 km long up to 30 km wide, extending from the Jorat (NE of Lausanne) in the west to near Schaffhausen in the east. They reach the greatest thickness in the area of Berne (5).

The Bernese sandstones belong to the Upper Marine Molasse and were deposited in the rather shallow Peri-Alpine sea, during Burdigalian times (late Lower Miocene) (7).

Quarries for the Bernese sandstones are usually situated where these rocks at outcrop are thickly bedded. They can be massive or may contain marl or mica layers between the sandstone beds. Mostly the sandstones are homogeneous, but sometimes they contain layers with marl clasts or pebbles.

At outcrop the Bernese sandstones display a wide range of colours, from bright yellow, grey, green to blue, depending on the degree of alteration of iron containing minerals, mainly glauconite (10).

The sandstones are usually fine to medium-grained. Petrographically, they are characterized as arkoses. As detrital grains they contain mainly quartz (40-45%), feld-

spars (20-30%) and less frequently micas, calcite, epidote and opaque minerals. The cement is mainly formed by calcite and less often by dolomite (total carbonate content 20-30%). Clay minerals (illite, chlorite, smectite) make up 2% to 8% of these rocks.

### 3. WEATHERING BEHAVIOUR

The weathering phenomena of the "Granitic sandstones" and of the "Platten sandstones" on buildings and in natural outcrops were described in detail by Zehnder (8), (9). In this contribution the same terminology will be used as defined in these works.

Granular disaggregation is the disintegration of the stone into individual component grains (4), (8), (9). It loosens the stone to a depth of more than 1cm, causing crumbling into sand and flakes, but it may also only affect the outermost few layers of grains.

This kind of deep disintegration is the most typical weathering phenomenon on Bernese sandstones in natural outcrops and on buildings. The whole sandstone is usually affected, so that corners and edges become rounded and on the planes the outermost grain layer can easily be wiped away. In sheltered parts it often shows a flaky character (see fig. 1).

Granular disaggregation can also commonly be observed on Platten sandstones but on Granitic sandstones it is restricted to strongly affected areas (8), (9).

Contour scaling is characterised by the formation of a crumbling zone at a depth from less than 1mm to about 20mm beneath the seemingly undamaged surface of the stone (4). It is clearly controlled by the exposure and it is dominantly found on the weather-facing sides of buildings. This form of alteration is especially characteristic of the Granitic sandstones (8), (9).

Bernese sandstones do show this kind of weathering phenomenon too, but it is much less frequent and it is restricted to the highly exposed sides of buildings, where it usually only affects the central planes of very homogeneous stones. Additionally, it is found on sites where the rock is often wetted quickly, e.g. stones above cornices, where during intense rain the water splashes back from the cornice.

Crust formation results in the covering of the stones surface with a deposit which is commonly black in colour. The crust is mainly composed of gypsum mixed with soot particles. Such crusts are clearly restricted to sheltered areas, such as recesses underneath cornices and ledges.

On Bernese sandstones only crusts of a maximum thickness of about 1mm can be observed. Such crusts are very weakly attached to the stone and easily fall off.

Efflorescence, i.e. loose aggregates of soluble salts, is periodically observed to appear and disappear on the surface of stones, as these minerals are very mobile (2). In the urban area of Berne magnesium and calcium sulphate are the predominant efflorescence salts found on masonry. Sodium sulphate and potassium nitrate are observed less frequently. Other salts, such as sodium carbonate, are restricted to areas contaminated by cement mortars. On natural outcrops calcium, magnesium and sodium sulphate were observed, of which calcium sulphate seems to be the most abundant.

Other weathering phenomena, such as spalling and exfoliation (4), (8), are rarely developed in the Bernese sandstone, and will therefore not be discussed here.

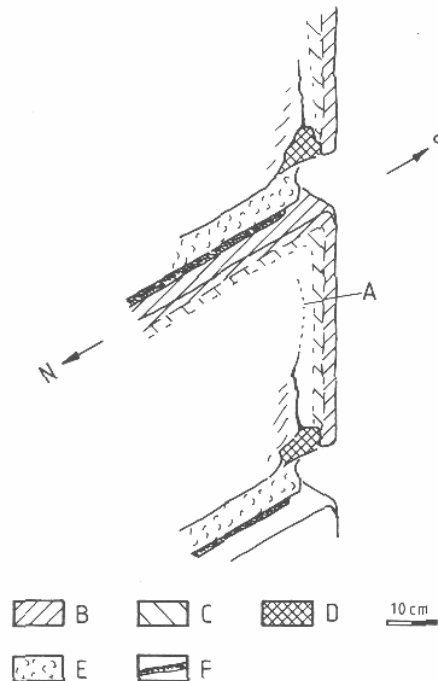

*Fig. 1: Sketch of a projecting ashlar forming a "belly" (A) in its central plane. A: Swollen "belly", B: Seemingly hardened, darker parts, C: Brighter parts as a result of deposition of very fine clay particles, D: Missing parts due to the beginning of contour scalling, E: Flaking, F: Very thin dark crust in sheltered parts.*

Swelling is an expansion of the stone that exerts its effect to a depth of up to 20cm. It is found in marl-free rock types, where it can be observed especially well on projecting ashlar (s. fig. 1), where a kind of a "belly" forms in the central planes, whereas edges and corners are darker and seemingly hardened. In a more advanced stage, this swelling can lead to a contour scaling.

Although this swelling is very typical for marl-free Bernese sandstones, it was never observed on ashlar of similar exposure containing layers of small marl clasts (1 to 5mm thick, 1 to 2cm in diameter). The edges of these stones are rounded and they show the same bright colour as their central planes. The marl clasts are usually eroded.

To explain the different behaviour of marl-free and marl-containing sandstones with respect to swelling, a series of tests have been started including observations on thin sections, measurements of the expansion through water absorption, distribution of pore radii, behaviour towards capillary water absorption and drying.

In the following part of this contribution some interesting observations on the water absorption through capillary forces and on drying of marl-free and marl-bearing samples is reported. As the tests are still in progress quantitative results will only be given at a later stage.

## **4. WATER ABSORPTION THROUGH CAPILLARY FORCES**

### **4.1 Method**

Rectangular prisms (4x4x10cm) were cut perpendicular to the bedding. They were dried to constant mass and then placed, with the long axes orientated vertically, in a tank 5mm deep filled with deionized water. The tank was covered to ensure a constant relative humidity near 100% and to avoid an overlapping of capillary forces with evaporation. These test arrangements are basically the same as described by Bousquie (3), except that an automatic water supply system was not installed as the sandstones tend to absorb water very quickly and evaporation out of the covered tank can be considered very slow.

After fixed time intervals the boundary between the darker wet and the brighter dry area was marked on one of the vertical planes of the samples. This was repeated until the water front reached the top of the sample.

Subsequently, the samples were left in the tank until 48 hours after the beginning of the test. They were then removed from the tank and exposed to normal laboratory conditions (21°C, relative humidity about 40-50%), and it was observed where the surface of the samples dried first.

This procedure was carried out for marl-free and marl-containing samples of different average grain size.

### **4.2. Observations**

#### **4.2.1. Wetting**

In all samples the speed of water suction became progressively slower with time, with the water level rising in a linear manner with the square root of time. In the medium-grained sandstones the water rose faster than in the fine-grained sandstones.

In all marl-free sandstones the wet to dry boundaries formed straight, horizontal lines on the vertical planes of the samples (fig. 2b) as the water rose everywhere in the sample with the same speed.

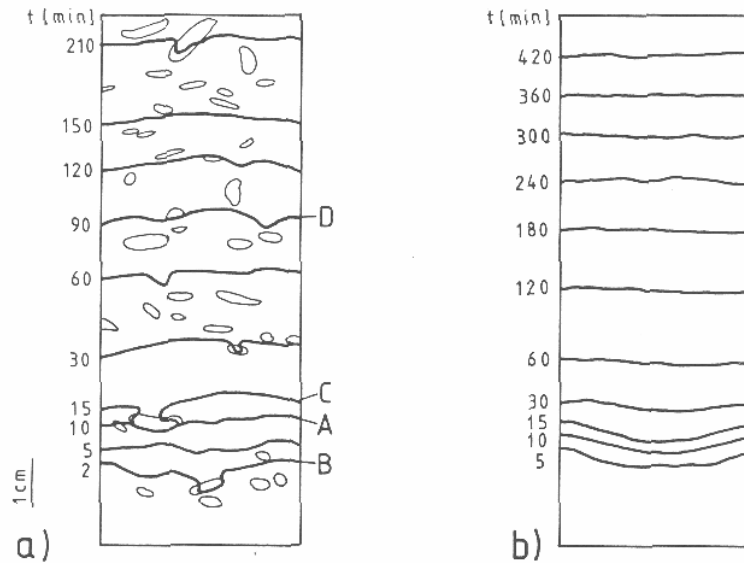

**Fig. 2:** Lines of the water level at fixed measured times in a sample containing abundant marl clasts (a) and in a marl-free sample (b). (See as well fig. 3)

In the marl-containing samples the wet to dry boundaries form a series of irregular, undulose curves (fig. 2a) as the water rises much more slowly inside the marl than in the surrounding sandstone (fig. 2a, line A). Directly above the clasts the water also rises slowly, as the water supply to these parts of the sample is obstructed (fig. 2a, line D). This observation of the water front moving into and around marl clasts is sketched in detail for a single clast in fig. 3a to 3d, with time progressing from a to d.

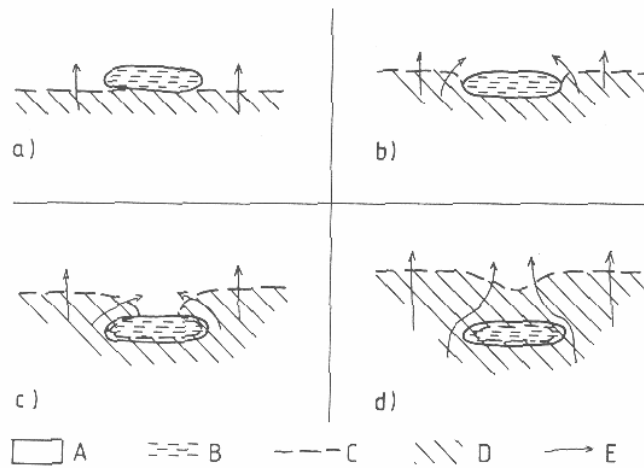

**Fig. 3:** Water front moving through a marl clast. A: sandstone, B: marl, C: water level, D: wet area, E: flow directions

- The water level has just reached the bottom of the marl clast, it is still forming a straight line (see also fig. 2b, line A).
- On both sides of the clast the water has reached the level of the top of the clast, but no wetting of the marl is yet visible (see also fig. 2b, line B, right side of the clast only).
- The water front in the surrounding rock is already well above the clast, but only a thin strip of the lower rim and the sides of clast are wetted (see also fig. 2b, line C).
- The rim of the clast is wet, but the centre is still dry and the water front is depressed in the area above the clast (see also fig. 2b, line D).

#### 4.2.2. Drying

The surface of all the marl-free samples dried firstly in the corners, then at the edges, thirdly in the centre of the free planes and at last at the bottom plane, with the medium-grained samples drying slower than the fine-grained sandstones.

The surfaces of the marl-bearing samples dried with basically the same succession as the marl-free samples. However, the centre of the marl clasts became dry very early in the drying sequence, when the rims of the clasts and the surrounding rock were still wet. However this dry area in the centre of the clasts only expanded very slowly, so that the surrounding stone became dry well before the rims of the clasts.

#### 4.2.3. Salt precipitation

Most of the samples exhibit minor quantities of efflorescence of gypsum after drying, suggesting that the salts are probably derived from the stone itself.

In marl-free samples the salt was exclusively observed in the upper corners and edges of the prisms, i.e. in the corners and edges that were reached last by the water front in the water absorption test. In marl-containing samples the salts were mainly observed in the centre of the clasts situated in the upper part of the samples, although some salt was also found in edges and corners.

### 4.3. Discussion

#### 4.3.1. Wetting

To consider the observation on wetting Poiseuille's law can be applied. This law describes the maximum possible speed of water transport through capillarity (1).

Poiseuille's law:

$$\Delta V / \Delta t = \frac{R^4 \pi \Delta P}{8 \eta L}$$

$\Delta V / \Delta t$	=	volume of fluid passing through 1cm <sup>2</sup> of pores during time t
$\eta$	=	viscosity of the fluid
$\Delta P$	=	pressure difference from the fluid reservoir to the end of the capillary path
$L$	=	length of the capillary path
$R$	=	average radius of the pores

From this formula it can be shown that the water rises in a capillary system linearly with the square root of time (3). Furthermore, this law indicates that the speed of water transport is strongly dependent on the size of the average pore radius, as R is raised to the fourth power, and that the increase is inversely proportional to the length of the capillary path.

In the marl-free sandstones the water rises linearly with the square root of time throughout all the samples, but with a slower speed in the fine-grained sandstones. According to Poiseuille's law we can, therefore, expect the average pore radius to be smaller in the fine-grained sandstones than in the medium-grained ones. This observation will have to be compared with the results of the measurements on the distribution of pore radii and with the observations on thin sections.

The following model for a porous body with its capillary suction curve is used to discuss the observations on wetting of different samples. Consider a body consisting of a layer of a material with a narrow average pore radius  $r$  ( $R > r$ ) and on top of this again a layer of material with radius  $R$ . In this theoretical body we can expect the following capillary suction curve (fig. 4), with the steepness of the slope representing the speed of the water front rising in the sample. Firstly the water level rises with a uniform speed throughout all the bottom layer. At point A the rising speed will reduce because of the smaller average pore radius of the middle layer.

When the water front has reached the top layer (at point B) the water motion will not speed up again as the water supply from below cannot increase, because it is obstructed by the middle layer with its small average pore radius.

*Fig. 4: Model of water rising in a porous body containing a layer with a small average pore radius ( $r$ ) sandwiched between two layers with a larger average pore radius ( $R$ ), such that  $R > r$ . (Explanation see text).*

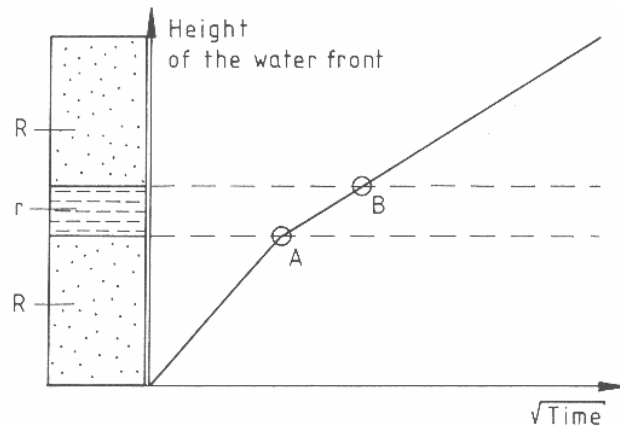

In a first approach, marl clasts can be regarded as layers of a material with a small average pore radius, although with a limited extension. According to the above model (fig. 4) the water will move through this layer slower and above the clast water motion would be hindered as well. However, this model is too simplified to completely describe the process because some clay minerals in the marl can absorb water, which will no longer be available for capillary transport. Furthermore, these clay minerals may swell when they absorb water and thereby filling some of the open pore space and thus hindering the water transport. This would have the effect that the water supply to the centre of the clasts would become progressively slower not only with time but also with distance from the rim.

The water moving into the sandstone area above the clast is rising through a capillary path that is bent around the clast. This path is longer than the path for the water rising beside the clast, so that the water front can reach a higher level beside the clast than above it for the same time unit.

#### 4.3.2. Drying

When the rate of water evaporating from the sample is faster than the transport speed of water ( $V/t$ ) to the surface, the front of liquid water will retreat into the sample (1) and the surface will become dry.

The moisture content at the moment when the liquid water is retreating into the sample is defined as the critical water content (6). During the initial part of the drying process the drying rate is proportional to the size of the free surface of the sample.

In the corners of the sample the surface is three times as large as in the central plane of the sample for the same volume unit. Therefore, evaporation is much quicker in the corners than in the central planes.

The surface of a porous body will dry quicker the slower the water transport from inside (1). This may partially explain why the finegrained sandstones dry quicker than the medium-grained sandstones. Other influences, such as possible differences in the critical moisture content, will be tested and reported at a later stage.

At present the drying behaviour of the marl clasts cannot be explained. More observation will be necessary to fully understand this process. However, the following processes probably play a role in the drying.

Some of the water in the marl clasts can be expected to be absorbed by the clay minerals, resulting in a slower drying of the marl clasts compared with the surrounding rock because evaporation of water that is absorbed in minerals takes place much slower than evaporation of water contained in open pores (6). Swollen clay minerals can also hinder the water supply to the centre of the clast so that it is possible that at the beginning of the drying period the moisture content in the centre of the clasts is lower than in the rims.

#### *4.3.3. Salt precipitation*

While raising through the sample the water dissolves the soluble salts of the stone. This process would only end if the solution becomes saturated.

Because the salts are exclusively found on the upper parts of the samples, we must expect a gradient of salt concentrations in the solution. this concentration gradient can develop in the following way. The top layer of the moving solution will pass through a section of the sample first and it will dissolve and remove the salts that are contained in this section. When the following layer of solution arrives at the same section of the sample most of the salts will already be removed. Therefore, it can be expected that the salt concentrations are higher at the top of the solution than at the bottom. When drying the remaining solution in the sample becomes more and more saturated and salts can precipitate from it.

The water front arriving at the marl clasts will bring salts into the clasts. As the solution only moves very slowly through the clasts these salts are not washed out of the marl again by the following parts of the solution and as a result they become concentrated in the marl.

## **5. SUMMARY**

The typical weathering phenomenon on marl-free Bernese sandstones is a swelling. On stones containing layers with marl clasts this swelling was not observed. Initial observations indicate that one difference between the marl-containing and the marl-free stones is that the marl clasts seem to act as salt traps. For a full explanation of the causes of swelling in the marl-free sandstones awaits the results of further tests.

## 6. BIBLIOGRAPHY

- (1) AMOROSO, G.G. & FASSINA, V. (1983): Stone Decay and Conservation Atmospheric Pollution, Cleaning, Consolidation and Protection. Elsevier, Amsterdam - Lausanne - Oxford - New York.
- (2) ARNOLD, A. (1981): Salzmineralien in Mauerwerken. Schweiz. Mineral. Petrogr. Mitt. 61, p. 147-166.
- (3) BOUSQUIE, P. (1979): Texture et Porosité de Roches Calcaires. Thèse Univ. Pierre et Marie Curie, Paris.
- (4) QUERVAIN, F. DE (1945): Verhalten der Bausteine gegen Witterungseinflüsse in der Schweiz, Teil 1. Beitr. Geol. Schweiz., geotech. Ser. , 23.
- (5) QUERVAIN, F. DE (1969): Die nutzbaren Gesteine der Schweiz. Verlag Kuemmerli und Frey, Bern.
- (6) SNETHLAGE, R. (1984): Steinkonservierung 1979-83. Arbeitsheft Bayrisches Landesamt f. Denkmalpflege, Heft 22.
- (7) TRUEMPY, R. (1980): Geology of Switzerland, a Guide Book, Part A. Wepf & Co., Publishers, Basel, New York.
- (8) ZEHNDER, K. (1979): Weathering of Molasse Sandstones on Monuments and Natural Outcrops. 3rd int Cong. Deterior. Preservation of Stones, Venice, 24-27 Oct.
- (9) ZEHNDER, K. (1982): Verwitterung von Molassesandsteinen an Baudenkmalern und Naturaufschlüssen. Beitr. geol. Schweiz., geotechn. Serie 61 .
- (10) ZGRAGGEN, P. & PETERS, Tj. (1980): Verwertbarkeit karbonathaltiger Molassesandsteine als Rohstoffe fuer dampfgehaertete Baustoffe. Beitr. geol. Schweiz., geotechn. Serie 59.

### Many thanks to:

Dr. A. Arnold,	Inst. f. Denkmalpflege, ETH Zuerich, for direction and supervision
Stuart Burley,	Geol. Inst., Univ. Bern, for helpful suggestions and for correcting the English
Brigitta Schaer,	Min.-Petr. Inst., Univ. Bern, for typing the manuscript.